

Instruction Manual

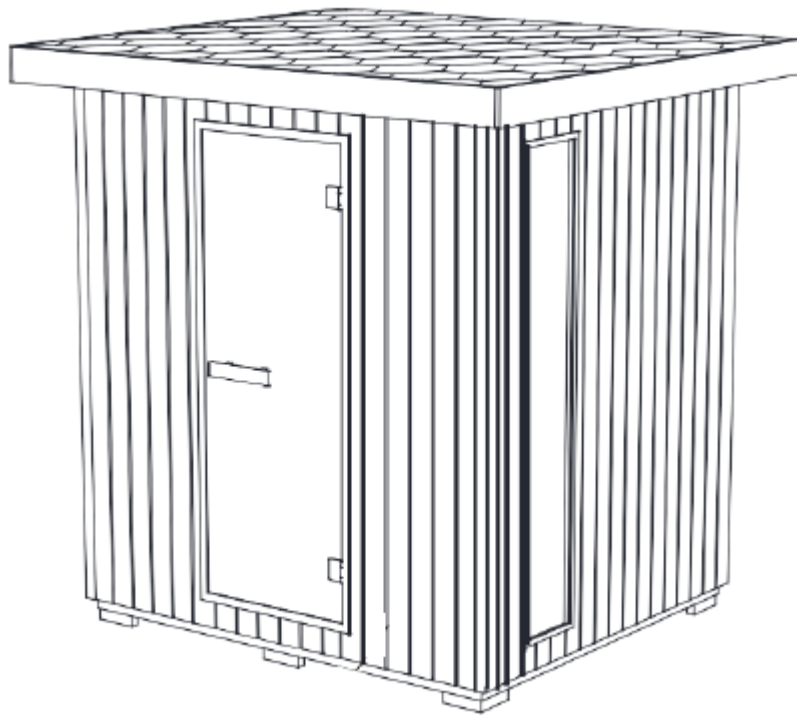

— Infrared makes life more healthy —

Due to our continued product improvement, product illustrated on this instruction manual may vary slightly from the actual product.

Recommendations

Read this manual carefully before using your sauna for the first time.

We recommend you keep it in a safe place for future reference.

- Wood is a living element, to maintain its original appearance, it is important to treat the outside of the wood against moisture. Use a saturator only on the outside of the sauna.
- Install the sauna on a perfectly flat and hard surface.
- Do not use liquid cleaning products. Disconnect the sauna before cleaning and use a wet rag .
- Protect the sauna's electrical cable to avoid it being crushed or pinched.
- Prior to replacing certain components, ensure that they are specified by the manufacturer or that they have the same features as the original parts. Incorrect replacement can cause a fire, a short circuit or damage to the sauna. We strongly recommend using a qualified technician.
- To avoid the risk of burns or electric shocks, do not use any metal tools.
- Do not put animals in the sauna.
- Do not leave the sauna switched on without supervision.
- Do not leave the sauna switched on for more than 3 hours at a time to avoid premature deterioration of the equipment. After 3 hours continuous usage, switch off the sauna for at least one hour.
- We recommend that you do not install a locking system on the sauna door.
- Check compliance of your electrical installation prior to connecting your sauna to the power supply.

Safety

IMPORTANT :

Please read the safety instructions carefully before installing and using your sauna cabin. They are essential for your safety, so please adhere strictly to them.

Beware of hyperthermia, heat stroke or heat exhaustion which can be caused or aggravated by noncompliance with the safety instructions. Symptoms are fever, a rapid pulse, dizziness, fainting, lethargy and numbness in all or part of the body. The effects are: reduced awareness of the heat, ignorance of imminent risks, loss of consciousness.

The sauna must not be used by:

- Children under 6 years of age.
- People with severe reactions to sunlight.
- Elderly or disabled people.
- People with previous medical conditions such as heart disease, high or low blood pressure, blood circulation problems or diabetes without prior medical advice.
- Pregnant women. Excessive temperature can endanger the foetus.
- Persons suffering from dehydration, open sores, eye disorders, burns or sunstroke.

Children between 6 and 16 years of age may use the sauna provided that they are continuously supervised by a responsible adult and that the temperature does not exceed 60°C (140°F).

In the event of problems involving health, medication or injury to muscles or ligaments, do not use the sauna without previously consulting a doctor and obtaining approval.

If surgical implants are worn, do not use the sauna without previously consulting a doctor and obtaining his approval.

Do not use the sauna after strenuous activity.

Wait 30 minutes for your body to cool down.

Do not spend more than 40 minutes in the sauna at any one time.

Do not consume alcohol or drugs before or during the session.

Do not sleep in the sauna when it is in operation.

To avoid the risk of overheating, connect your sauna to a sufficiently powerful electrical outlet and do not connect other electrical equipment to the same wall socket.

To avoid any risk of electrocution or damage to the sauna, do not use it:

- During thunderstorms.
- If the electrical cable is damaged, it must be replaced by a qualified person.
- If the electrical cable overheats, it must be checked by a qualified person.
- If you have to change a bulb, wait until the sauna is switched off and cooled down.

Dry your hands before connecting or disconnecting the electricity.

Never work with wet hands or feet.

Do not switch the electricity or the heating system rapidly on or off as this could damage the electrical system.

Do not try to repair the sauna by yourself without the agreement of the sauna's distributor or manufacturer.

Unauthorized attempts to repair it will invalidate the manufacturer's warranty.

Do not use any type of detergent inside the sauna.







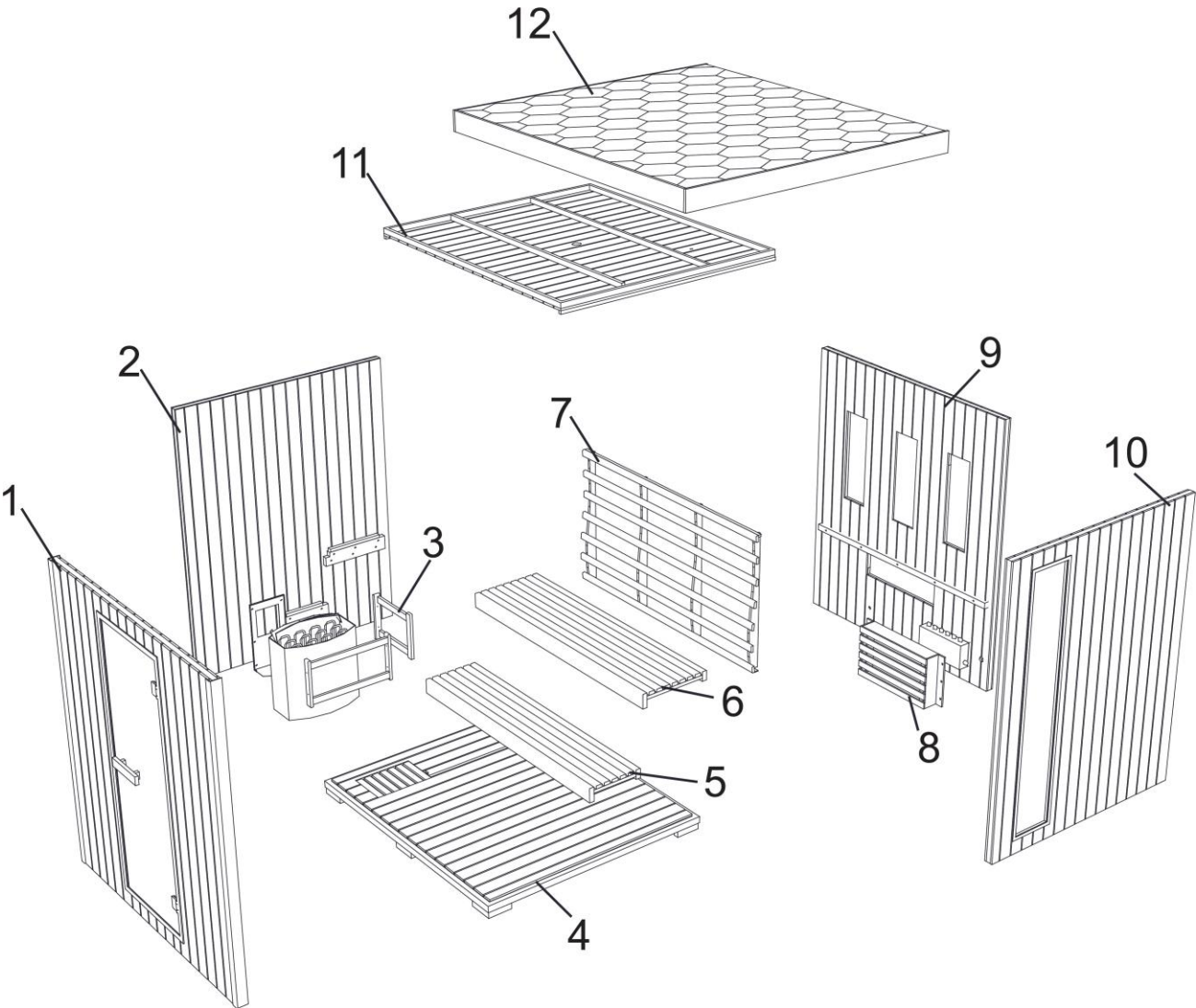

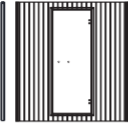
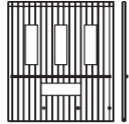
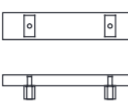
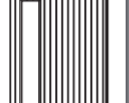

Do not pile up or store objects inside or on top of the sauna.

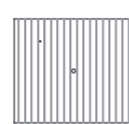
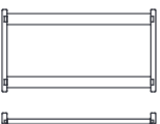
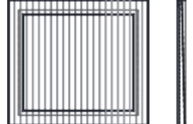
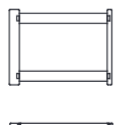

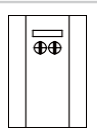
Do not place flammable materials or chemical agents near the sauna.

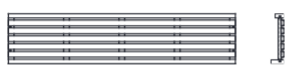
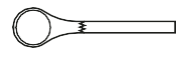
Description sauna

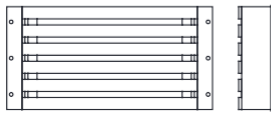
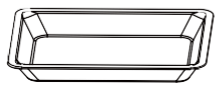

Description sauna

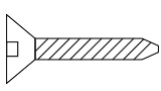
1.1		(1715x1820x54mm)1x	9		(1597x1820x54mm) 1x
1.2		(250x50x45mm) 2x	10		(1456x1820x54mm) 1x
2		(1456x1820x54mm) 1x	11		(1656x1420x42mm) 1x
3.1		(560x300x40mm) 1x	12		(2015x1815x120mm)1x
3.2		(408x300x40mm) 1x	13		1x Cable
4.1		(1654x1454x55mm) 1x	14		1x Sauna stove
4.2		(750x40x30mm) 1x	15		1x Wooden barrel
5		(1592x350x90mm) 1x	16		1x Wooden spoon
6		(1592x450x90mm) 1x	17		1x Hygrometer
7		(1580x848x80mm) 1x	18		1x Hourglass
8		(680x340x115mm) 1x	19		1x Water pan

					
Ø5x50	Ø4x50	Ø4x30	Ø3x25	Ø6x50	
6x	12x	12x	6x	2x	2x

Read the assembly instructions carefully before starting.

Choice of location

Designed solely for exterior installation.

Select a space:

- In a dry area, on a flat stable surface that can support the weight of your sauna.
- The height must be sufficient for you to reach the ceiling and carry out electrical connections and maintenance.
- Away from any source of water, flames or flammable materials.

Practical advice

- Note that sauna assembly requires 3 adults.
- Clearly identify each panel before you begin
- During assembly, position your sauna's mains cable so that it is easily accessible.
- Note that there are variations between the models.

IMPORTANT :

Please check the countersink and hole diameter of the drill holes to avoid damaging the wood.

Tools needed



Screwdriver



Tape measure



Pencil



Cutter



2 Spanner

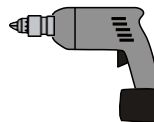

Electric
screwdriver



Wood spiral drill



Allen Wrench



Step ladder

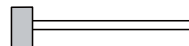

Mallet

Assemble instructions

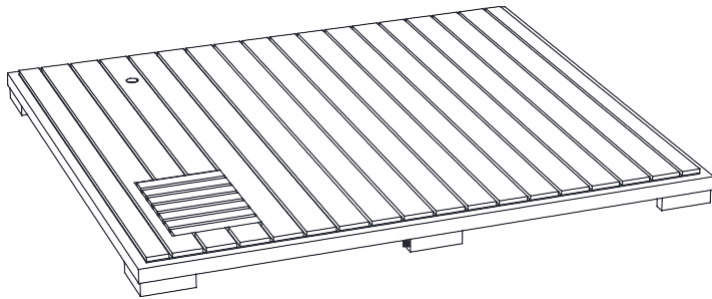

→ Take out the bottom panel and place it on a flat ground for installation.

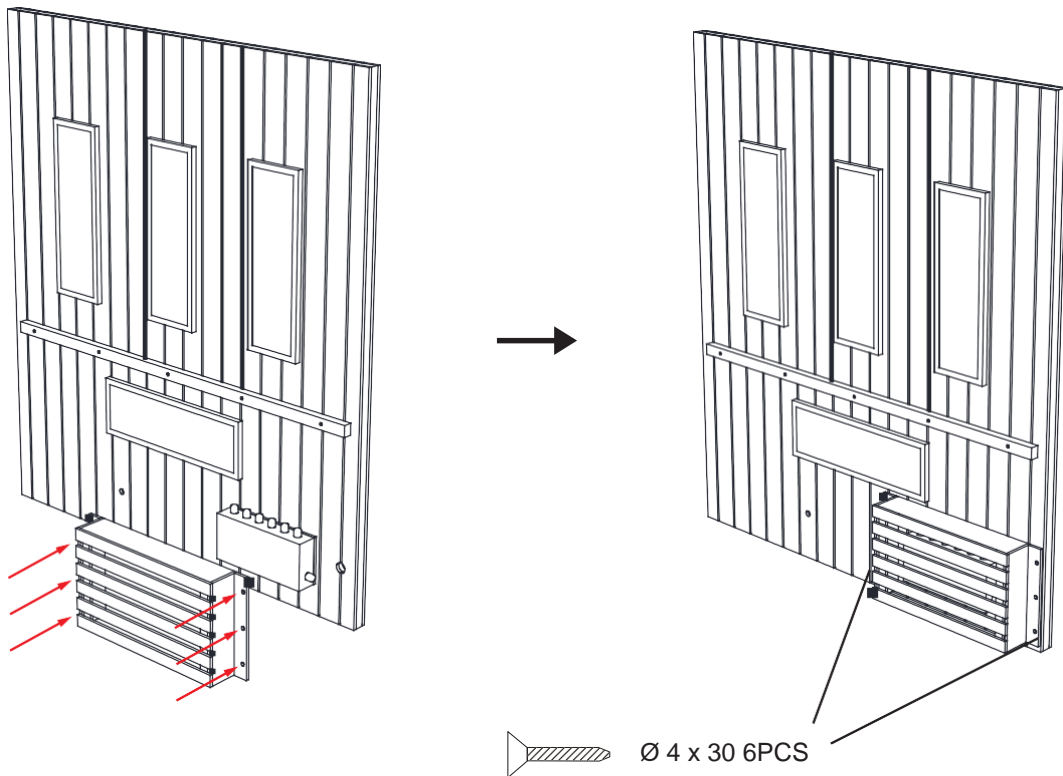

Remove the rear panel and control box protective frame, and install the control box protective frame outside the rear panel control box with screws to provide protection.

Assemble instructions

Assemble steps

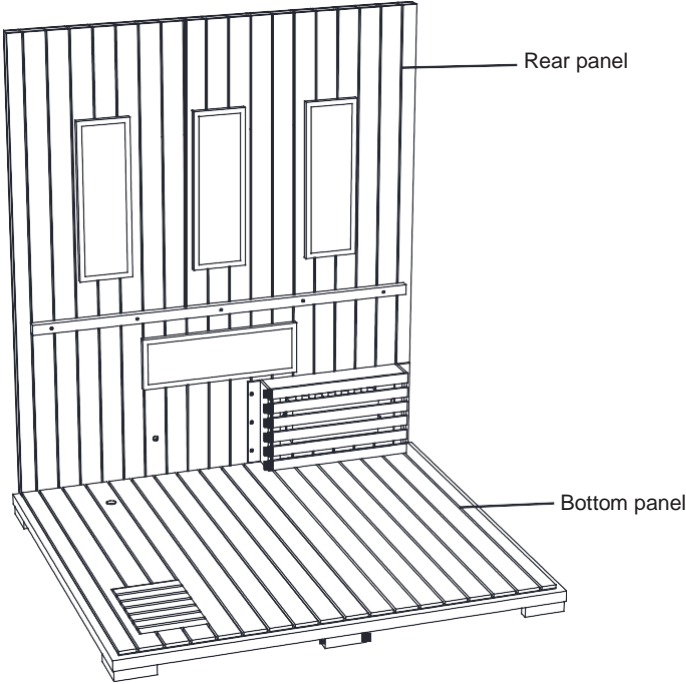

Place the assembled rear panel above the corresponding position on the bottom panel.

The left and right side panels are fixed to the rear panel through a buckle connection.

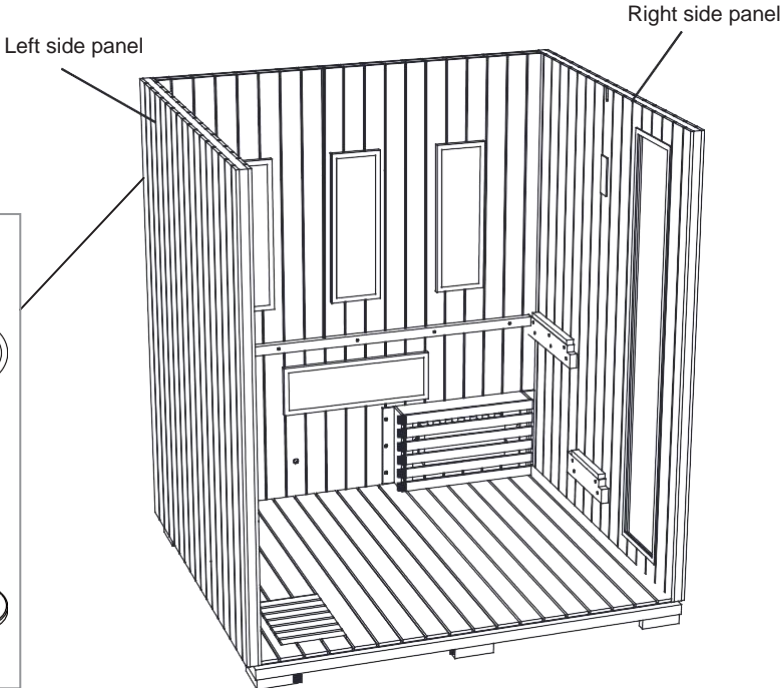
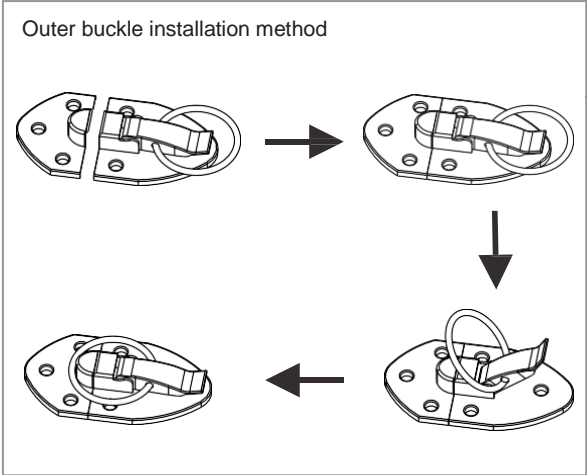

Assemble instructions

Assemble steps

The front panel and left and right side panels are also fixed through a buckle connection.

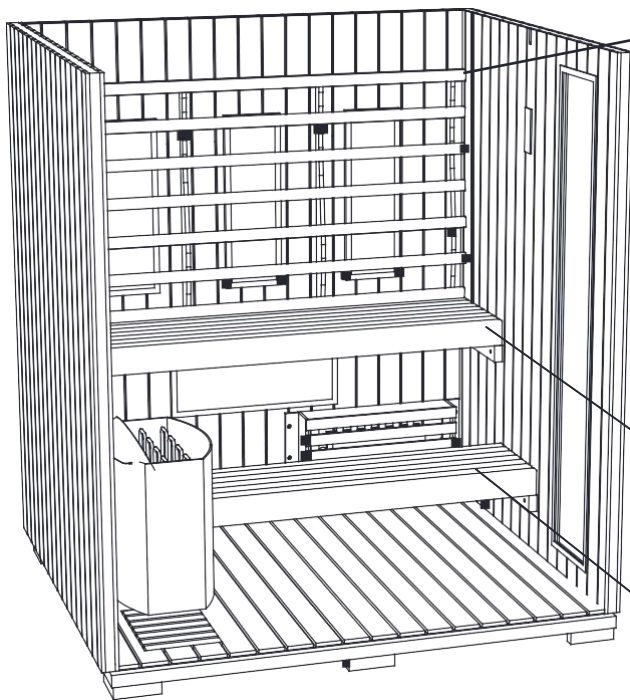
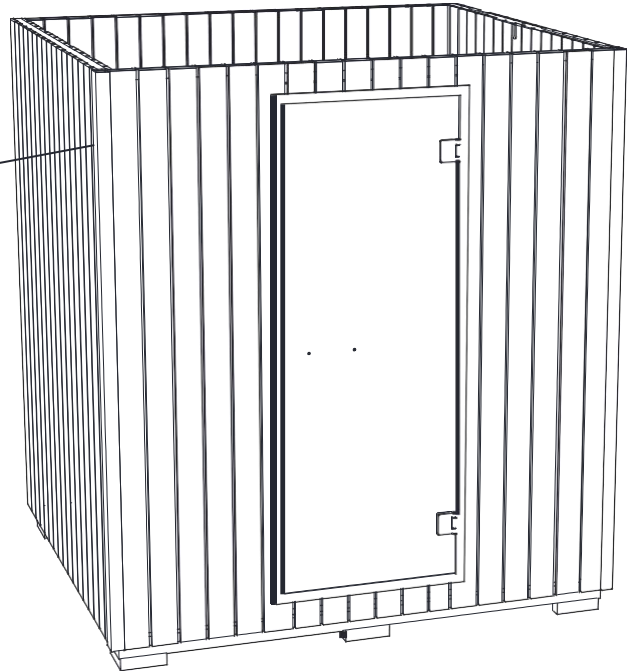
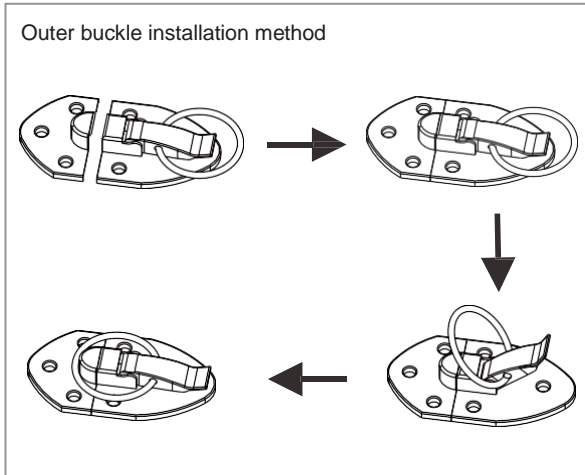

Backrest

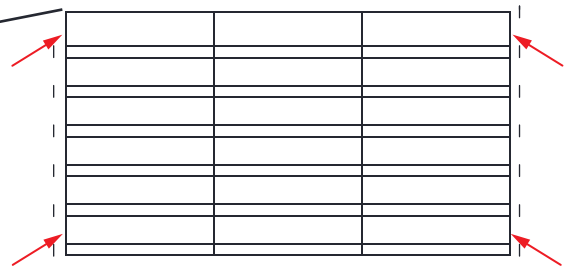

 Ø 4 x 50 4PCS



 Ø 4 x 50 8PCS

Assemble instructions

Assemble steps

The sauna cable runs through the hole in the bottom plate and is fixed to the bottom plate with a wooden square.

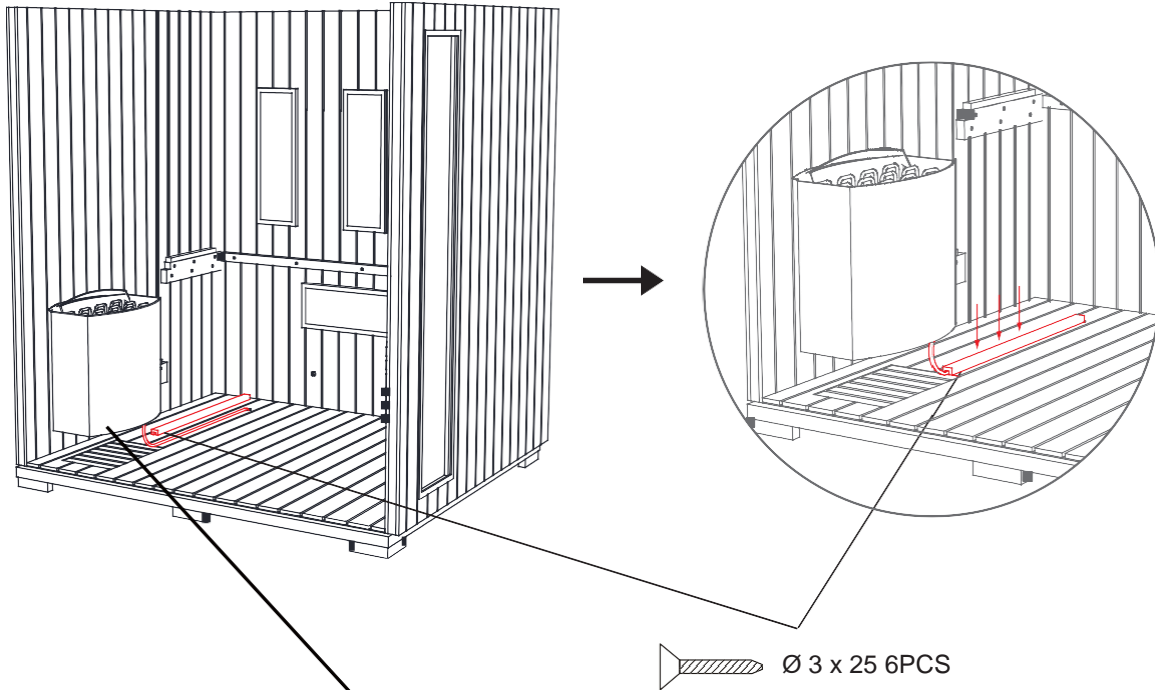

Installation diagram of sauna stove

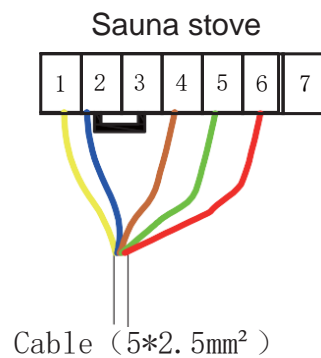
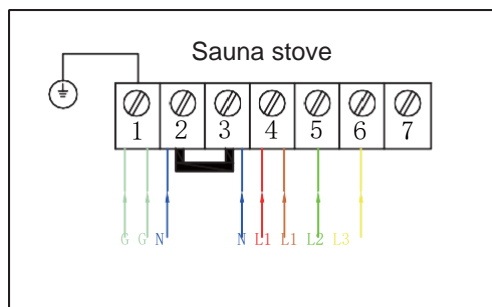
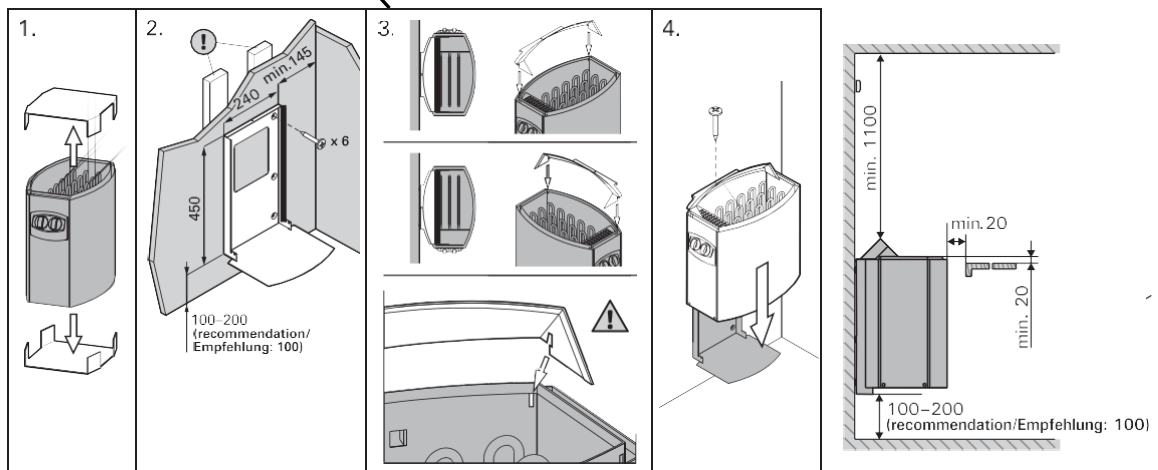

Assemble instructions

Assemble steps

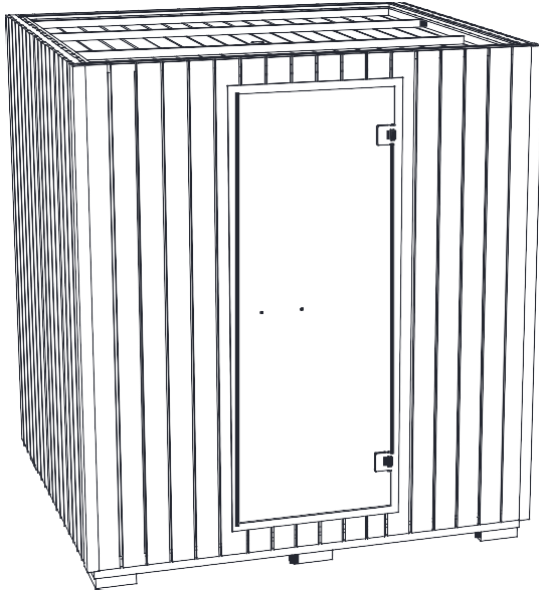

Install the inner top plate

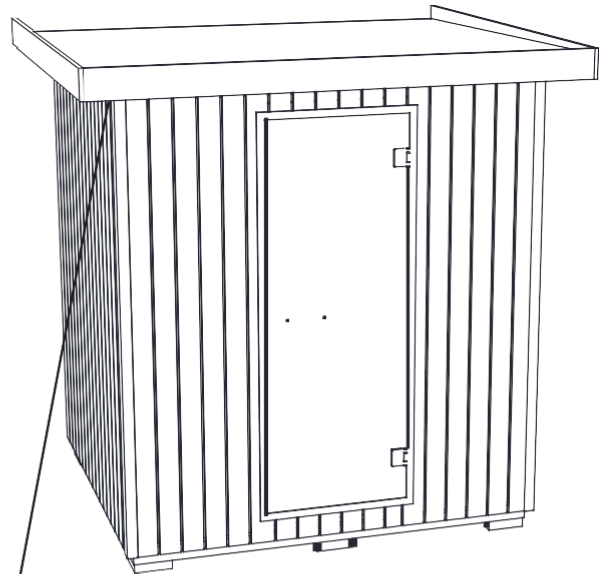

Install the outer top plate

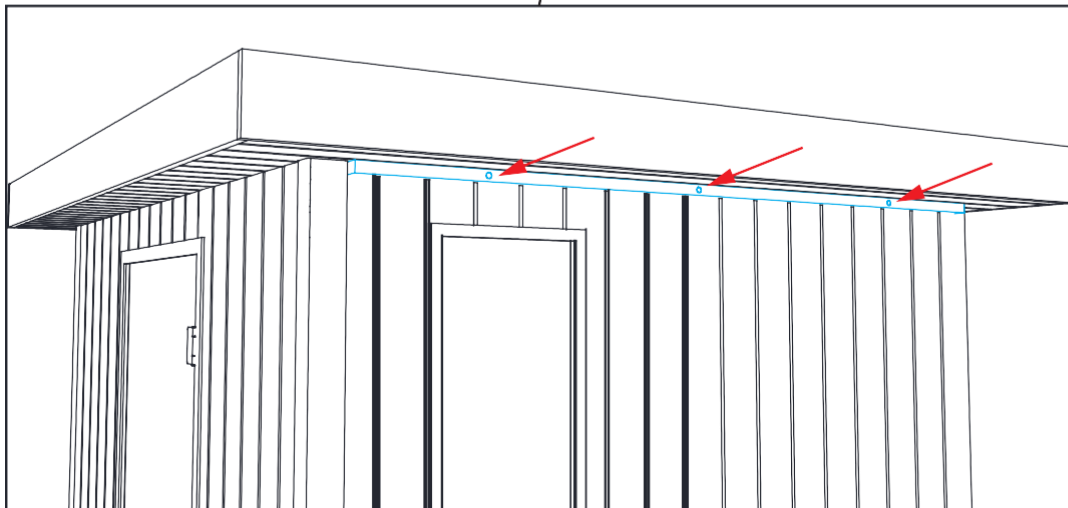

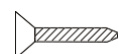
 Ø 5 x 50 6PCS

After installing the outer top plate, pay attention to connecting and fixing the wooden blocks on both sides of the top plate to the side plate through locking screws.

Assemble instructions

Assemble steps

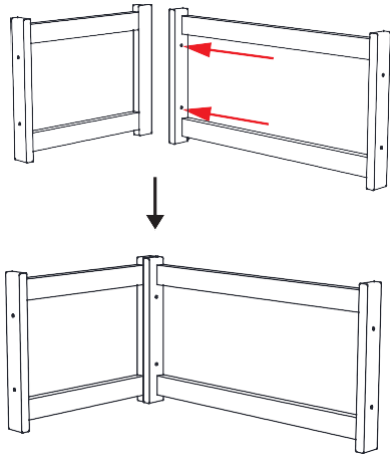

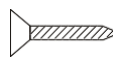
 Ø 4 x 30 2PCS

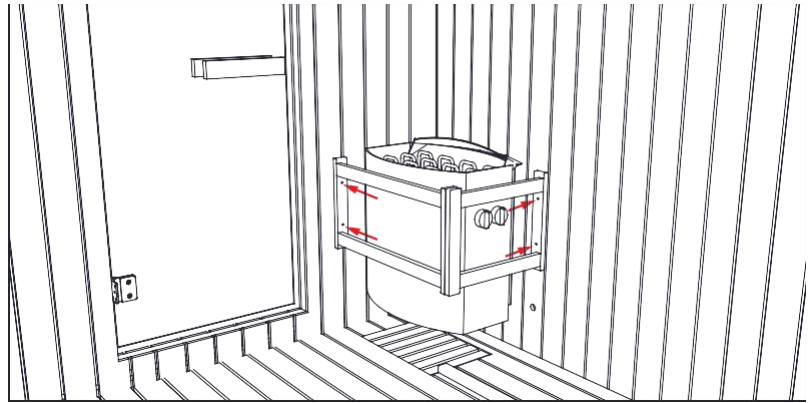

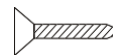
 Ø 4 x 30 4PCS

Install the sauna stove protection frame

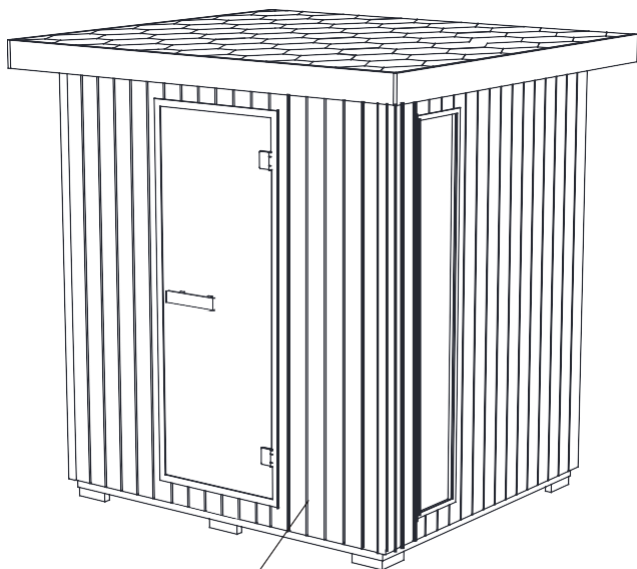

Front

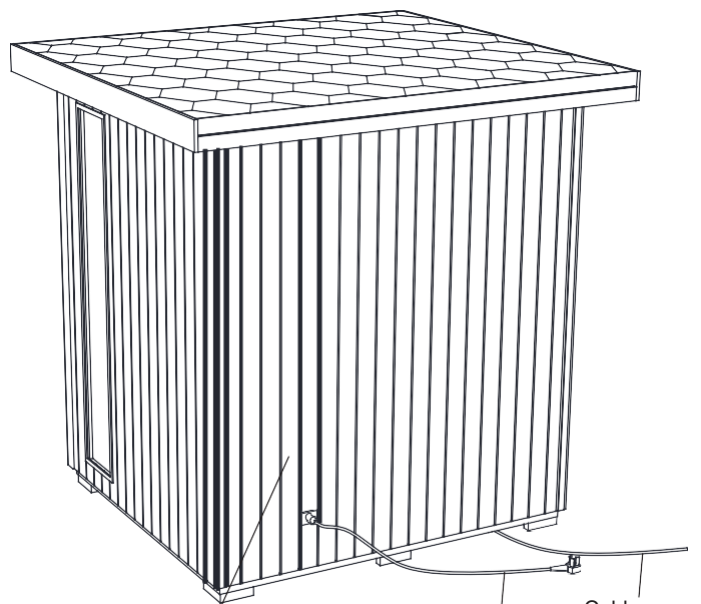

Back

Power plug

Cable
(5*2.5mm²)

Overview of the complete machine after installation

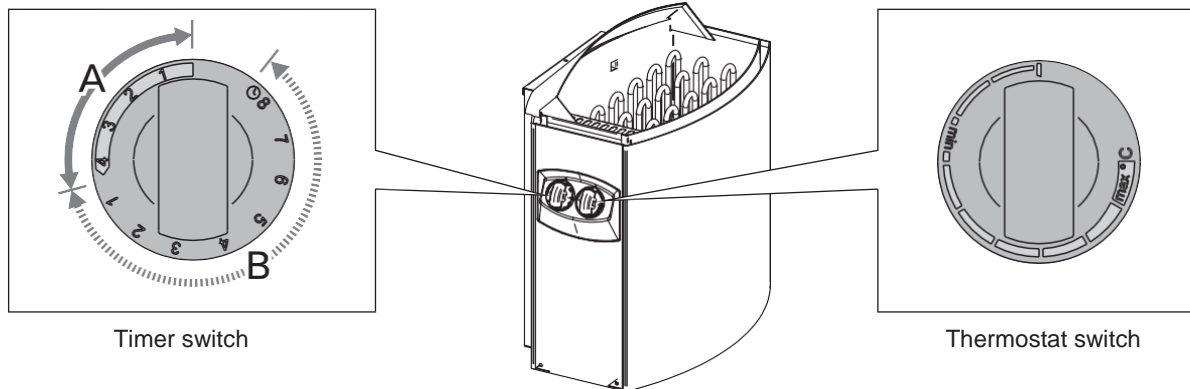

1. Heater On

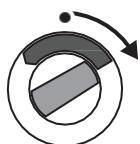

Turn the timer switch to the "on" section (section A in figure 2, 0–4 hours). The heater starts heating immediately.

2. Pre-setting Time (timed switch-on)



Turn the timer switch to the "pre-setting" section (section B in figure 2, 0–8 hours). The heater starts heating when the timer has turned the switch back to the "on" section. After this, the heater will be on for about four hours.

For more detailed information on the specific use and precautions of the sauna stove, please read the manual provided with the sauna stove.

Control panel operation

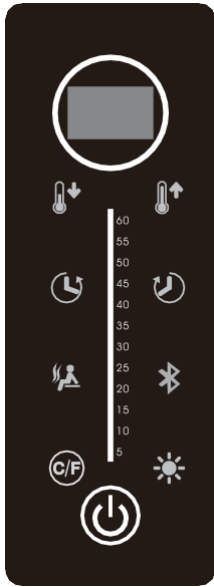

1. Switch on/power off

In energized state, the system is under standby, when first press button for 3 seconds, the system is switched on, the room temperature will display on the screen, when second press this button, the system and all loads will be turned off. If the button color shows green means on-state, and red color means closed.

2. Light wave function

Under the power on state, press button, start the light wave function, green button means turn on, and red means turn off, the light wave temperature will memory last setting, time is 60 minutes.

Light wave temperature setting: in light wave state, press button to adjust the temperature, the adjustment range is 30-70 degree, every press could increase only 1 degree, if no operation exceed 8 seconds, the screen will return to display the current actual temperature.

Press C/F button to change the temperature display between $^{\circ}\text{C}/^{\circ}\text{F}$.

Light wave time setting: in light wave state, press button to adjust time, the adjustment range is 5-60 minutes, every press could increase only 1 minute. If no operation exceed 8 seconds, the screen will return to display the current actual time.

3. Bluetooth audio function

Under the power on state, press button, start the Bluetooth audio function, green button means turn on, and red means turn off, turn on the Bluetooth function of your mobile device, search and pairing it, then listen to the music.

4. Light control system

Press button to turn on the color light (the light color memory last setting), green button means turn on, and red means turn off, under the light on conditions, long press this button 5 seconds could change the light color, every press could change only one color, cyclic Conversion and memory (L1 = white color, L2 = red+blue color, L3 = blue color, L4 = blue+green color, L5 = green color, L6 = green+red color, L7 = red color, L8 = every color mutation, L9 = every color Gradual) if no operation exceed 8 seconds, the system exit light control mode.

The system has a DV12V oxygen bar function, when system under standby mode, the oxygen bar function can immediately powered.

Fault detection and protection

1. High temperature protection

If the detection temperature of sensor has exceed 80 degree, the two digital tubes display "H-H" at the same time, the alarm flashed and all function stopped, even if the temperature drops to 75 degree, all function can not be restore anymore, it must be powered off first then powered on again.

2. Sensor fault detection

open circuit: Two digital tubes display "E0" and flash, buzzer alarmed, all function can not be open anymore, fault eliminated then can be used normally

Short circuit: Two digital tubes display "E1" and flash, buzzer alarmed, all function can not be open anymore, fault eliminated then can be used normally

Maintenance

Protection of wood

Brush each exterior barrel slat and apply a wood stain when full assembly to protect the wood.
This wood stain had to be renewed according to the recommendations of the product used

Maintenance

IMPORTANT :

Disconnect the cabin's power supply cable before undertaking any work.

Problems identified	Possible reasons	Solutions
Electric stove does not heat up.	Power supply cable disconnected.	Check power supply cable connection.
	The general power supply is cut.	Check that the switchboard and wall plug are working.
	Stove is overheat protected.	Refer to the electric stove manual.
Sauna light fitting no longer work.	Light cable not fully plug.	Plug the cable.
	Light is defective.	Contact your dealer.

Servicing

1. Disconnect your sauna.
2. Use a vacuum cleaner to remove dust from crevices in the woodwork.
3. Clean the cabin with a damp cotton cloth and use a small amount of soap if necessary. Rinse with a damp cloth.
4. Clean the glass with a window / glass cleaner and a soft colth.
5. Maintain the exterior of the sauna every 2 years with a suitable product.

IMPORTANT :

The wood should be treated with a protective product only on the outside of the sauna.

No treatment should be applied inside the sauna.

Do not use benzene, alcohol, chemical agents or strong detergents on the sauna since chemical products can damage the wood. Do not spray water on your sauna.

Please read the instructions provided with the sauna stove for the installation and use of the stove.

The heater may only be connected to the electrical network in accordance with the current regulations by an authorised, professional electrician.